

Trip amplifier

2231



- AC/DC trip amplifier
- 2 adjustable alarm limits
- Galvanically isolated 3.75 kVAC
- Front-programmable
- 3-digit LED display
- 24 VDC or universal supply



Advanced features

- The front-operated push buttons are used for programming the different standard functions.
- A password can prevent access for changing parameters.

Application

- Alarm detector in connection with measurement of AC/DC current or voltage signals.
- The unit is used where accurate setpoint setting and different alarm functions are required.
- The unit can be used as a single or dual trip amplifier.
- Used in applications where programmable parameters such as hysteresis, setpoint, reset, active relay for increasing or decreasing signal, delay and input signal need to be set.

Technical characteristics

- 3-digit display showing the input signal in %.
- Two LED indicating relay status.
- 3 pushbuttons for programming.
- Standard DC current input signals in the range 0...20 mA.
- DC voltage signals in the range 0...250 VDC.
- AC current signals up to 1 A.
- True RMS measurement of AC voltage signals in the range 0...250 VAC.
- Mounting for a standard 11-pole socket which can be adapted for DIN rail or plate use with PR's 7023 adaptor and 7024 mounting keying.

Connections

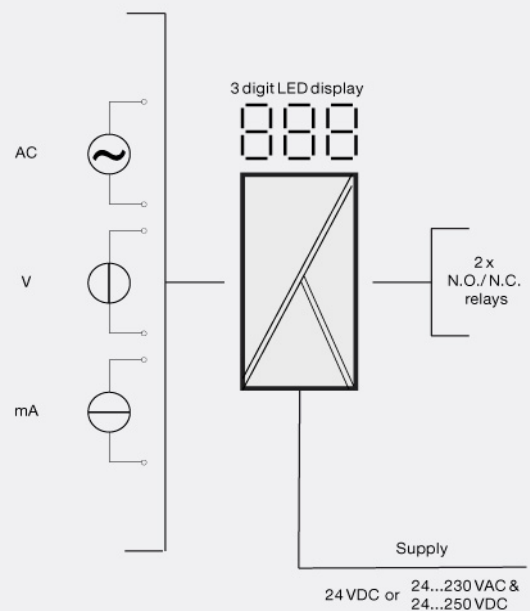

Order:

Type	Supply
2231	24 VDC : D 24...230 VAC / : P 24...250 VDC

Environmental Conditions

Specifications range.....	-20°C to +60°C
Calibration temperature.....	20...28°C
Relative humidity.....	< 95% RH (non-cond.)
Protection degree.....	IP50

Mechanical specifications

Dimensions (HxWxD).....	80.5 x 35.5 x 84.5 mm (D is without pins)
Weight DC / universally supplied.....	125 g / 175 g

Common specifications

Supply voltage.....	19.2...28.8 VDC
Supply voltage, universal.....	21.6...253 VAC, 50...60 Hz or 19.2...300 VDC
Internal consumption.....	1.5 W (2231D)
Internal consumption.....	2 W (2231P)
Isolation voltage, test / working.....	3.75 kVAC / 250 VAC
Response time (programmable).....	0.25...60 s (DC)
Response time (programmable).....	0.75...60 s (AC)
Updating time.....	100 ms
Accuracy.....	Better than 0.1% of selected range
Signal dynamics, input.....	16 bit
Effect of supply voltage change.....	< ±0.002% of span / %V
Temperature coefficient.....	< ±0.01% of span /°C (DC signals)
Temperature coefficient.....	< ±0.02% of span /°C (AC signals)
Linearity error.....	< 0.1% of span
Linearity error.....	< ±0.35% of span 50...1000 Hz (AC sine wave signals)
EMC immunity influence.....	< ±0.5%

Input specifications

Max. offset.....	50% of selected max. value
Current input: Measurement range.....	0...20 mA
Min. measurement range (span), current input.....	10 mA
Input resistance, current input.....	50 Ω
AC current input: Measurement range.....	0...1 ARMS
Min. measurement range (span), AC current.....	0.5 ARMS
Input resistance, AC current.....	1 Ω / 2 W
Voltage input: Measurement range.....	0...250 VDC
Min. measurement range (span), voltage input.....	0.5 VDC
Input resistance, voltage input.....	Nom. 5 MΩ
AC voltage input: Measurement range.....	0...250 VRMS
Min. measurement range (span), AC voltage.....	0.5 VRMS
Input resistance, AC voltage.....	Nom. 5 MΩ

Output specifications

Relay outputs: Setpoint setting.....	0...99.9% of span
Hysteresis.....	0...99.9% of span
Updating time.....	100 ms
ON and OFF delay.....	0.0...99.9 s
Max. voltage.....	250 VRMS
Max. current.....	2 AAC
Max. AC power.....	500 VA
Max. load at 24 VDC.....	1 A
*of span.....	= of the presently selected range

Approvals

EMC.....	EN 61326-1
LVD 2006/95/EC.....	EN 61010-1
PELV/SELV.....	IEC 364-4-41 and EN 60742
EAC TR-CU 020/2011.....	EN 61326-1