

GENERAL

ALIAVA The Alia AVF250 flowmeter is commonly used in location that required on-site analog flow indication. The meter accurately measures small volumes / wide ranges of liquids, gases and steam.

FEATURES

- ❑ 4 digit flowrate & 8 digit totalizer
- ❑ Local indication without auxiliary power
- ❑ 4-20 mA & scale pulse output
- ❑ Low pressure loss in gas and steam application
- ❑ Damper for Gas / Steam application
- ❑ Consistent overall length
- ❑ Heating jacket design
- ❑ Intrinsically safe & explosion proof for hazardous area

STANDARD SPECIFICATION

- Size : 0.59", 0.78", 0.98", 1.57", 1.96", 2.55", 3.15", 3.93", 4.92", 5.90", 7.87"
- Measuring Range : Liquid - 1 ~ 200000 Liter/Hr
: Gas - 0.03 ~ 4000 M3/Hr
- Turndown Ratio : 10:1 (20:1 Optional)
- Accuracy : +/-1.6% (Standard)
: +/-1.0% (Optional)
- Repeatability : +/-0.5% value of reading
- Material
 - Tube & Float : Stainless Steel 304
 - : Stainless Steel 316
 - : Stainless Steel 316L
 - : Stainless Steel + PTFE Liner
- Standard Pressure : 568.934 psi (0.59"... 1.96")
: 227.573 psi (2.55"... 7.87")
- Temperature : -112... +392 °F (Standard)
: -13... +212 °F (LCD Display)
: 0... +185 °F (PTFE Liner)
: -112... +752 °F (Optional)
- Flange Type : JIS 10K / JIS 20K / JIS 40K
ANSI 150# / ANSI 300# / ANSI 600#
DIN PN 10 / PN 16 / PN25 / PN 40
- Fluid Viscosity : 300 CP Max.
- Communication : RS485 (MODBUS Protocol)
HART signal (Compatible)



- Local Display : Mechanical Indicator (Standard)
Digit Display : 4 Digit Flowrate
: 8 Digit Totalizer
- Current Output : 4-20 mA (2 Wire)
Load : Max. 600
- Pulse Output : Open collector (Scale pulse)
Rating : 3 to 30Vdc, 100 mA Max.
- Data Storage : Operation parameters and totalizer figures are stored by EEPROM for more than 10 years
- Alarm Output : 2 point (Open collector)
Rating : 3 to 30Vdc, 100 mA Max.
- Keypad : 3 internal keys for programming and display control
- Ambient Temperature : -13... +140 °F
- Protection Class : IP 65
: Intrinsically Safe, Eex ia IIC T5
: Explosion Proof, Ex d IIB T6
- Housing Material : Aluminum Alloy
- Cable Entry : Standard :M20 Option:1/2"NPTF
- Pressure Loss : 0.995634 ~ 9.95634 psi
- Power Supply : 11 ~ 36VDC (2 wire 4-20 mA)
: Ni-MH Battery (3 years working hours)

➤ FLOW RANGE

Size				Float No.	S.S.304 / 316 / 316L	S. S. + PTFE	S.S.304 / 316 / 316L	
					Water , 20°C			Air, 0°C, 1 ATM
					Liter/Hr		Liter/Hr	M3/Hr
15 mm	1/2"	20 mm	3/4"	F15.0	1.0 - 10		0.03 - 0.3	
				F15.1	1.6 - 16		0.07 - 0.7	
				F15.2	2.5 - 25	1.6 - 16	0.11 - 1.1	
				F15.3	4.0 - 40	2.5 - 25	0.18 - 1.8	
				F15.4	6.3 - 63	4.0 - 40	0.28 - 2.8	
				F15.5	10 - 100	6.3 - 63	0.4 - 4.0	
				F15.6	16 - 160	10 - 100	0.7 - 7	
				F15.7	25 - 250	16 - 160	1.0 - 10	
				F15.8	40 - 400	25 - 250	1.6 - 16	
				F15.9	63 - 630	40 - 400	3.0 - 30	
25 mm	1"	40 mm	1-1/2"	F25.0	63 - 630			
				F25.1	100 - 1,000	63 - 630	3.0 - 30	
				F25.2	160 - 1,600	100 - 1,000	4.5 - 45	
				F25.3	200 - 2,000			
				F25.4	250 - 2,500	160 - 1,600	7.0 - 70	
				F25.5	320 - 3,200			
				F25.6	400 - 4,000	200 - 2,000	12 - 120	
				F25.7	500 - 5,000	250 - 2,500		
				F25.8	630 - 6,300	320 - 3,200	18 - 180	
50 mm	2"	65 mm	2-1/2"	F50.0	500 - 5,000			
				F50.1	630 - 6,300	400 - 4,000	18 - 180	
				F50.2	1,000 - 10,000	630 - 6,300	25 - 250	
				F50.3	1,600 - 16,000	1,000 - 10,000	40 - 400	
				F50.4	2,000 - 20,000	1,600 - 16,000		
80 mm	3"			F50.5	2,500 - 25,000		63 - 630	
				F80.0	1,600 - 16,000			
				F80.1	2,000 - 20,000			
				F80.2	2,500 - 25,000	1,600 - 16,000	70 - 700	
				F80.3	4,000 - 40,000	2,500 - 25,000	120 - 1,200	
100 mm	4"	125 mm	5"	F80.4	6,300 - 63,000	4,000 - 40,000	180 - 1,800	
				F100.0	4,000 - 40,000			
				F100.1	6,300 - 63,000	4,000 - 40,000	180 - 1,800	
				F100.2	8,000 - 80,000	6,300 - 63,000		
150 mm	6"			F100.3	10,000 - 100,000	8,000 - 80,000	300 - 3,000	
				F150.0	8,000 - 80,000			
				F150.1	10,000 - 100,000	8,000 - 80,000	300 - 3,000	
200 mm	8"			F150.2	15,000 - 150,000			
				F150.3	20,000 - 200,000			
				F200.0	15,000 - 150,000			
				F200.1	20,000 - 200,000			

➤ DIMENSIONS

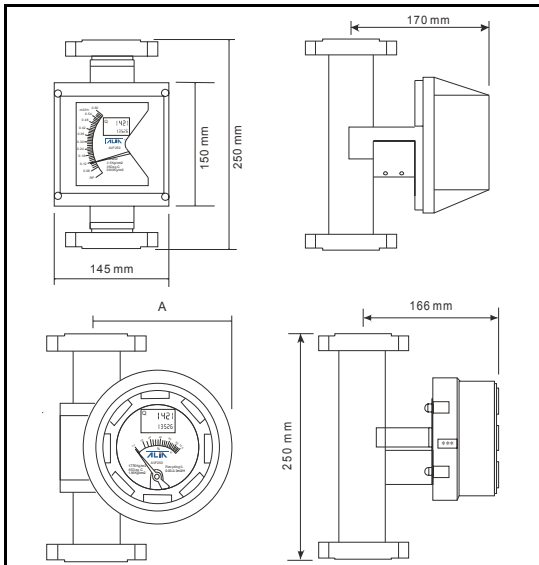

BT (Bottom - Top)			
Size mm	A mm	Weight Kg	ΔP mbar
15	173	3.7	140
25	173	5.2	190
50	173	8.7	230
80	173	14	330
100	173	15	420
150	178	34	600
200	180	49	700

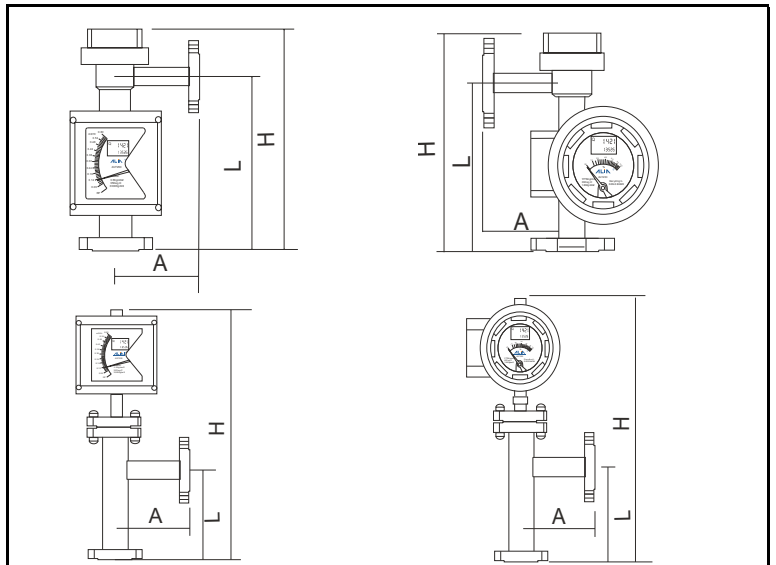

BR (Bottom - Top Side)					
Size mm	H mm	L mm	A mm	weight Kg	ΔP mbar
15 mm	350	250	120	7.0	180
25 mm	350	250	120	8.0	220
50 mm	600	250	120	15	280
80 mm	700	250	150	25	350
100 mm	700	250	150	29	450
150 mm	760	300	180	53	580
200 mm	800	350	200	61	700

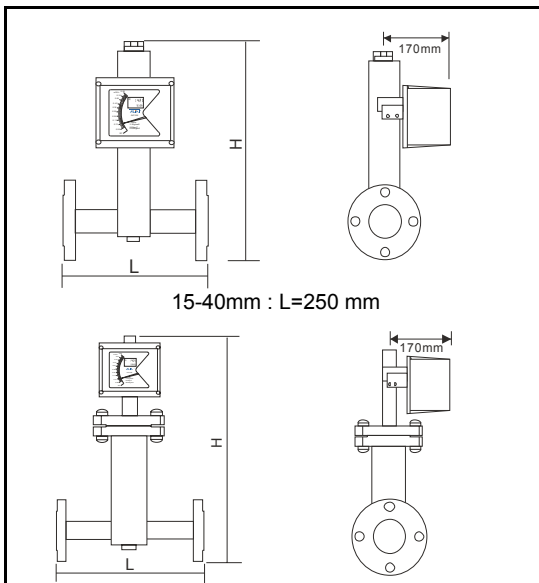

LR / RL (Horizontal)				
Size mm	H mm	L mm	weight Kg	ΔP mbar
15	430	250	6.5	300
25	450	250	10.5	350
50	540	250	21	400
80	557	400	32	450
100	570	400	48	500
150	620	400	95	630

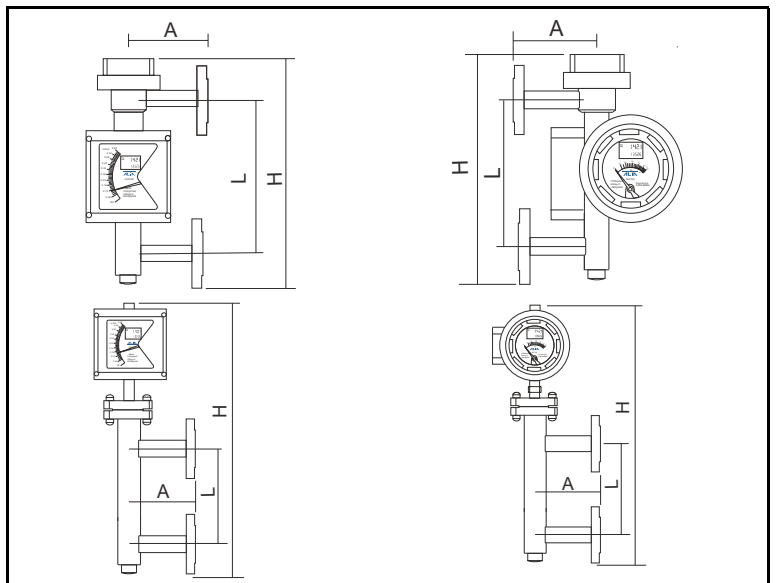

RR (Bottom Side - Top Side)					
Size mm	H mm	L mm	A mm	weight Kg	ΔP mbar
15	500	250	120	5.1	200
25	500	250	120	8.2	280
50	650	250	120	14	360
80	800	300	150	31	450
100	800	300	150	50	580
150	850	350	180	67	630
200	880	400	200	81	700

MODEL SELECTION GUIDE

AVF250 Series									
Example:AVF250-050-S6ABT-B-IT-D									
AVF250-	XXX	-XX	X	XX	-X	-XX	-X	Description	
Size	015 - 200							15 ~ 200mm (1/2" ~ 8")	
Material	-S4							Stainless Steel 304	
	-S6							Stainless Steel 316	
	-SL							Stainless Steel 316L	
	-4P							Stainless Steel 304+ PTFE Liner	
	-6P							Stainless Steel 316+ PTFE Liner	
Process Connection	1							PN10	
	2							PN16	
	3							PN25	
	4							PN40	
	A							ANSI 150 #	
	B							ANSI 300 #	
	C							ANSI 600 #	
	J							JIS 10K	
	K							JIS 20K	
	L							JIS 40K	
Z							Others		
Flow Direction	BT							Bottom - Top	
	BR							Bottom - Top Side	
	RR							Bottom Side - Top Side	
	LR							Left - Right (Horizontal)	
	RL							Right - Left (Horizontal)	
Function	- A							Local Indication	
	- B							Local Indication + Rate 4 digit/Totalizer 8 digit + 4-20 mA	
	- C							Local Indication + Rate 4 digit/Totalizer 8 digit (Battery Power)	
	- D							Local Indication + One point Alarm (Reed Switch, 1A, 30VDC)	
	- E							Local Indication + Two point Alarm (Reed Switch,1A, 30VDC)	
Protection Class	- NN							IP65	
	- IT							Intrinsically Safe, Eex ia IIC T5	
	- EX							Explosion Proof, Ex d IIB T6	
Option	-N							None	
	-C1							RS485 (Modbus Protocol)	
	-C2							HART Signal (Compatible)	
	-D							Damper (For Steam & Gas Application)	
	-H							Heating Jacket	
	-P1							Pulse/Alarm Output * 1 (With Function B Only)	
	-P2							Pulse/Alarm Output * 2 (With Function B Only)	
	-T							Max. Temp. Higher Than 200 °C (100 °C for LCD Display)	
-PT							Cable Entry 1/2" NPTF		